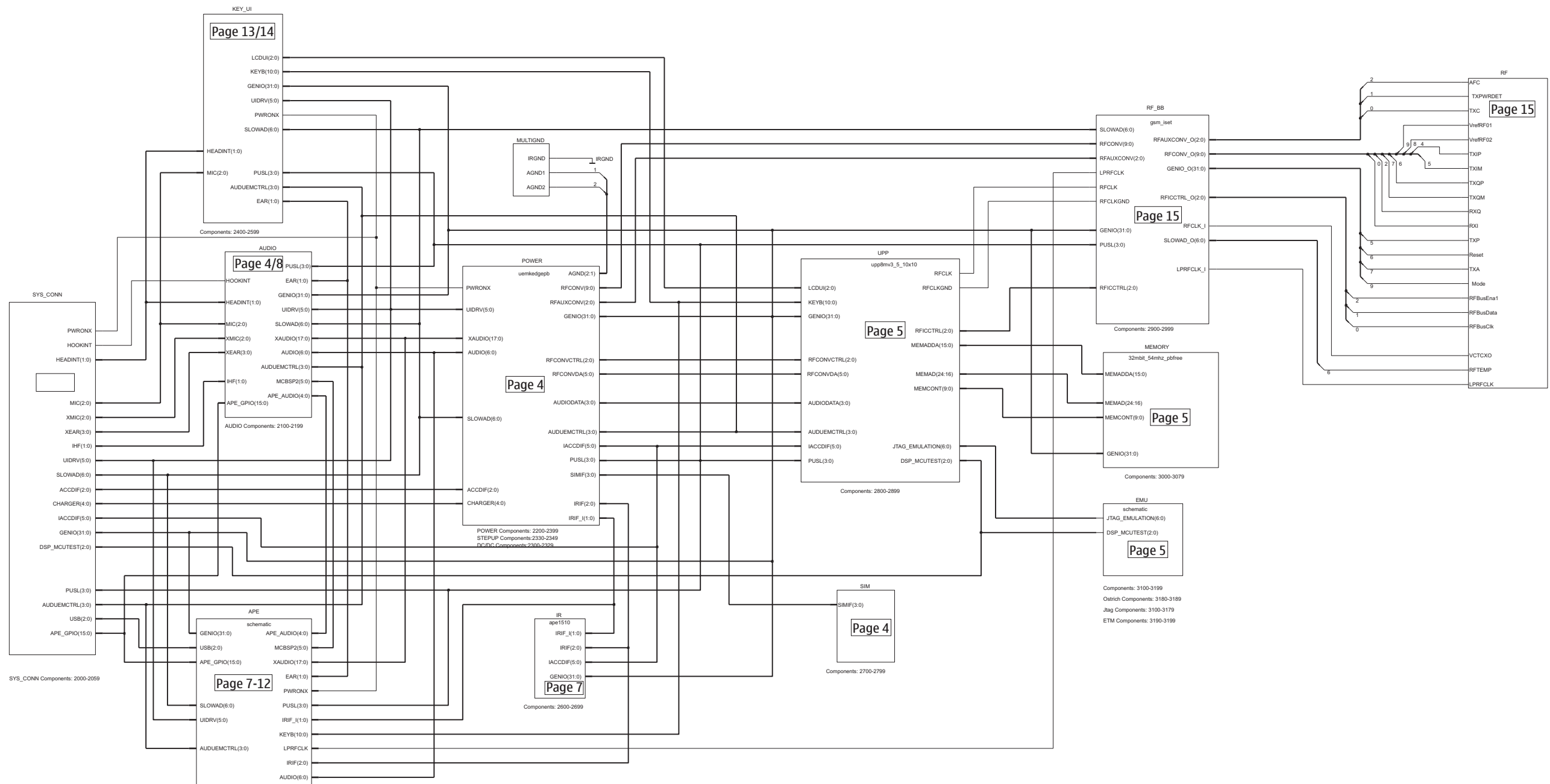
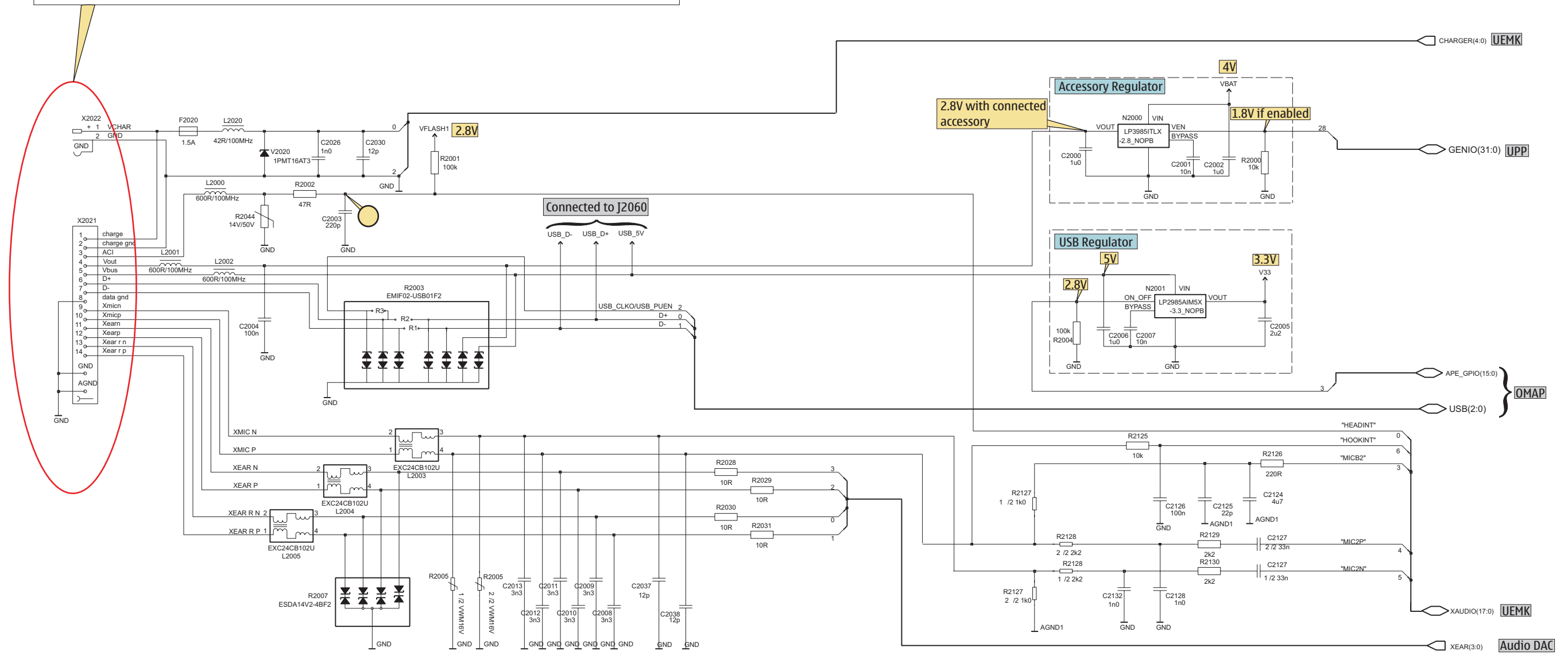
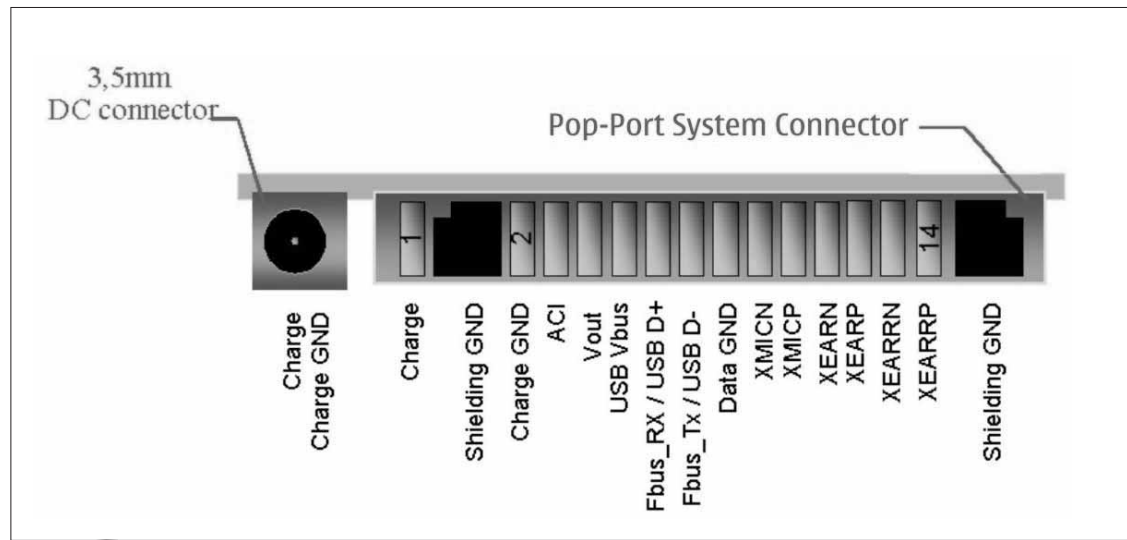

Table of Contents	Page no.
DCT-4 common baseband	2
UEMK, SIM, Zocus	4
UPP, Flash	5
APE overview connection	6
OMAP, IRDA, MMC	7
Audio DAC, Audio amplifier	8
Hinge Camera flex connector, interface	10
WLAN baseband	11
WLAN RF	12
QWERTY keyboard	14
RF-part	15
Signal overview Side 1	16
Signal overview Side 2	17
Component finder Top side	19

DCT-4 common baseband



System connector



UEMK, SIM, Zocus

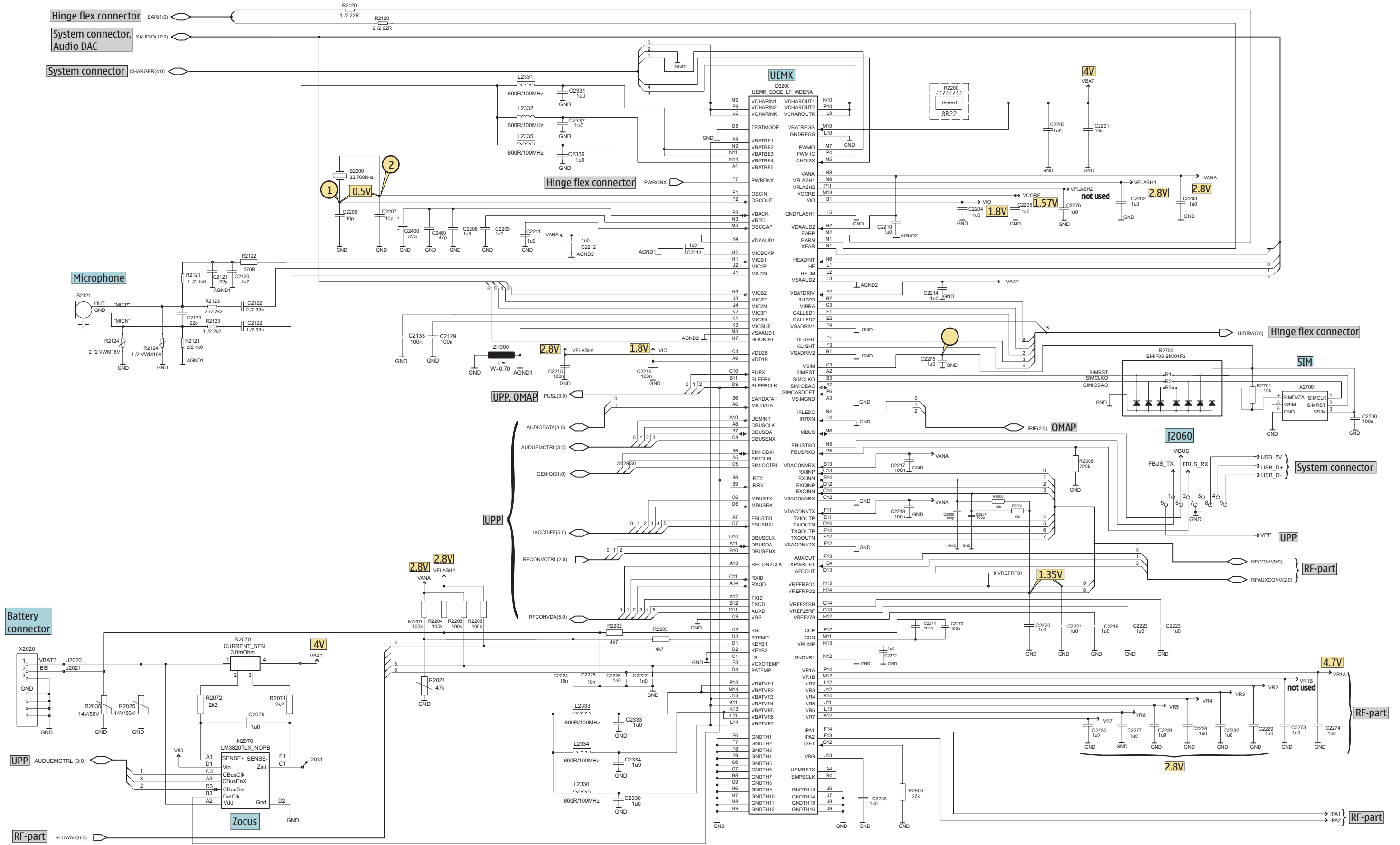

UPP, Flash

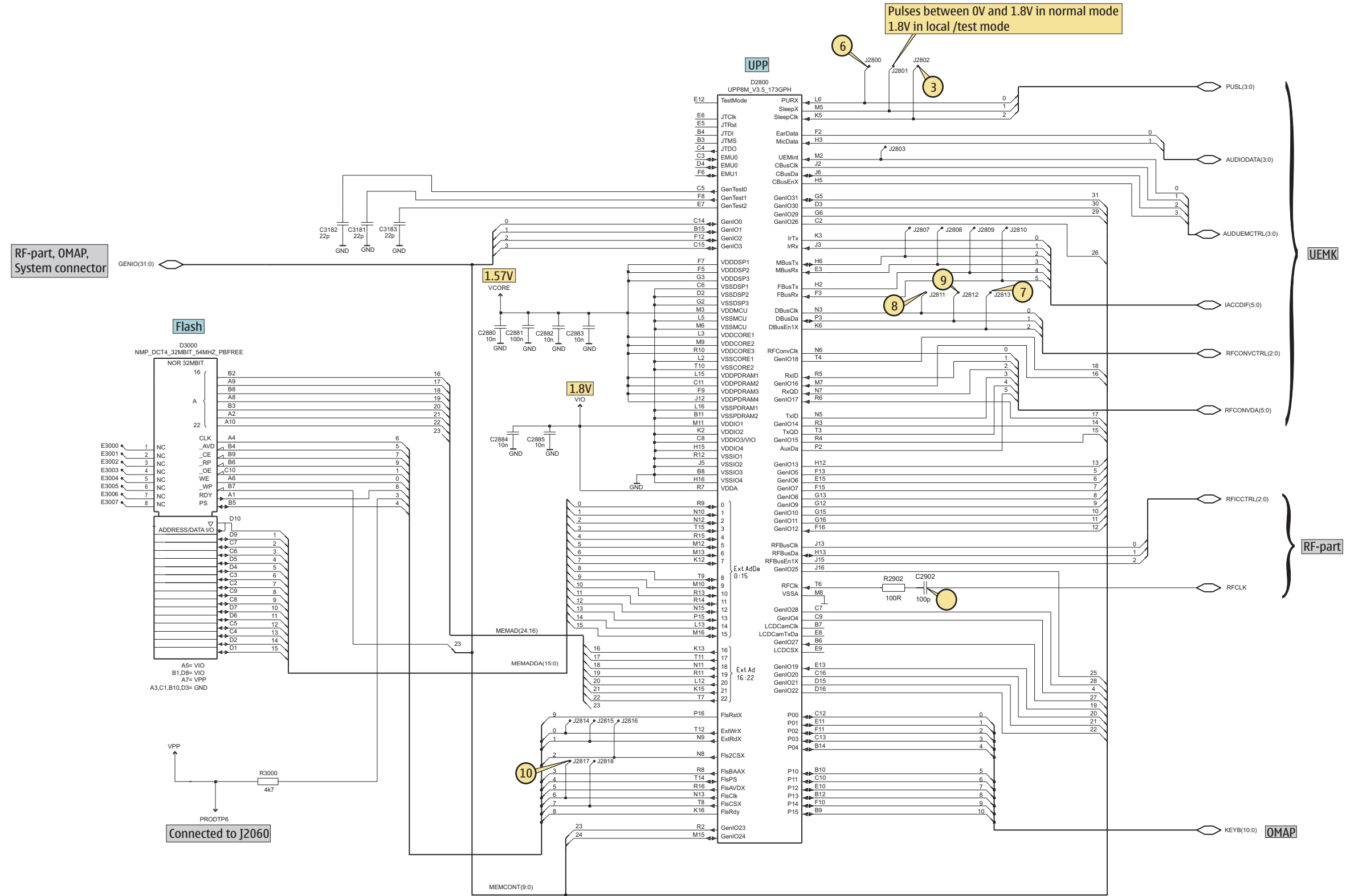

APE overview connection

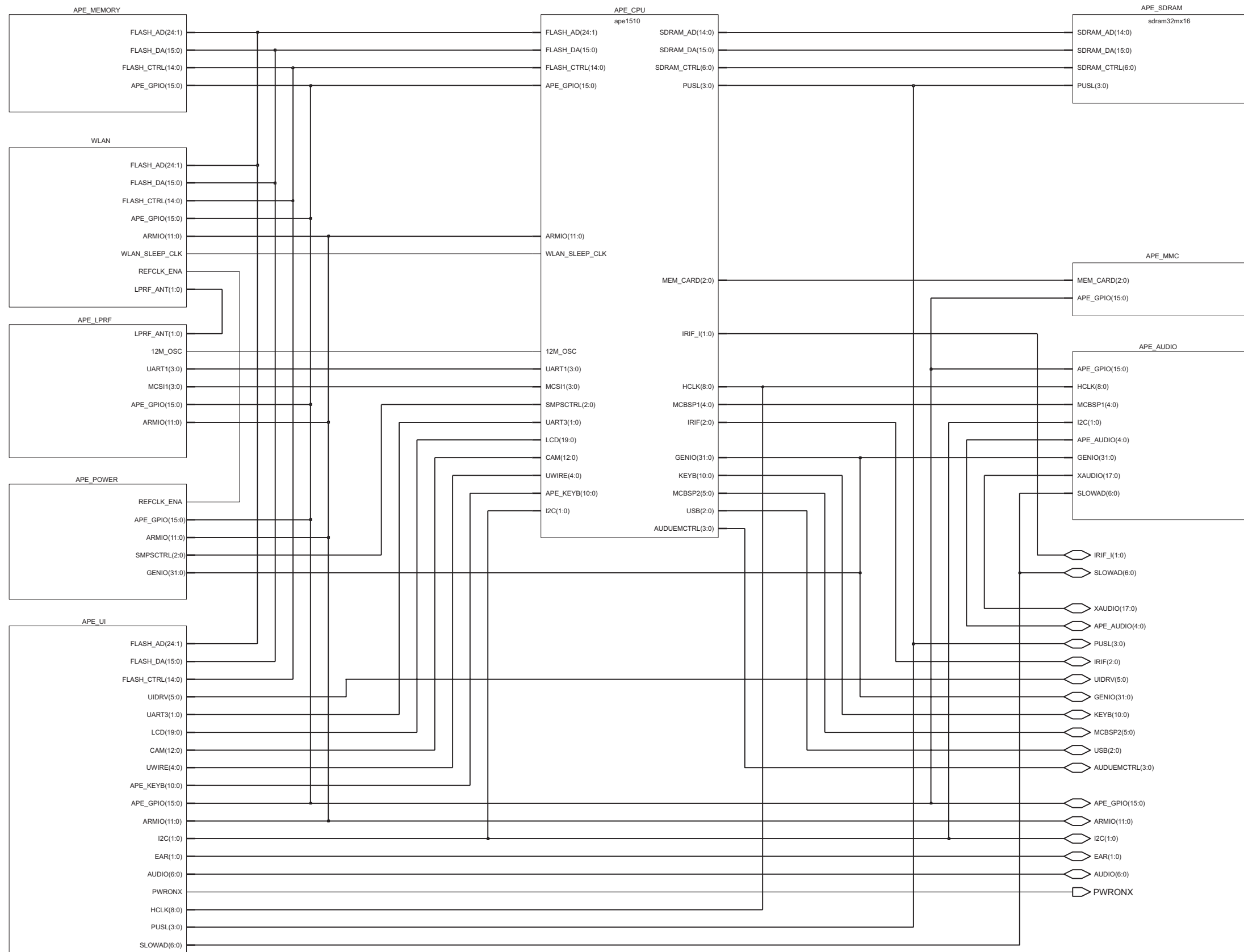

OMAP, IRDA, MMC

D4800
OMAP

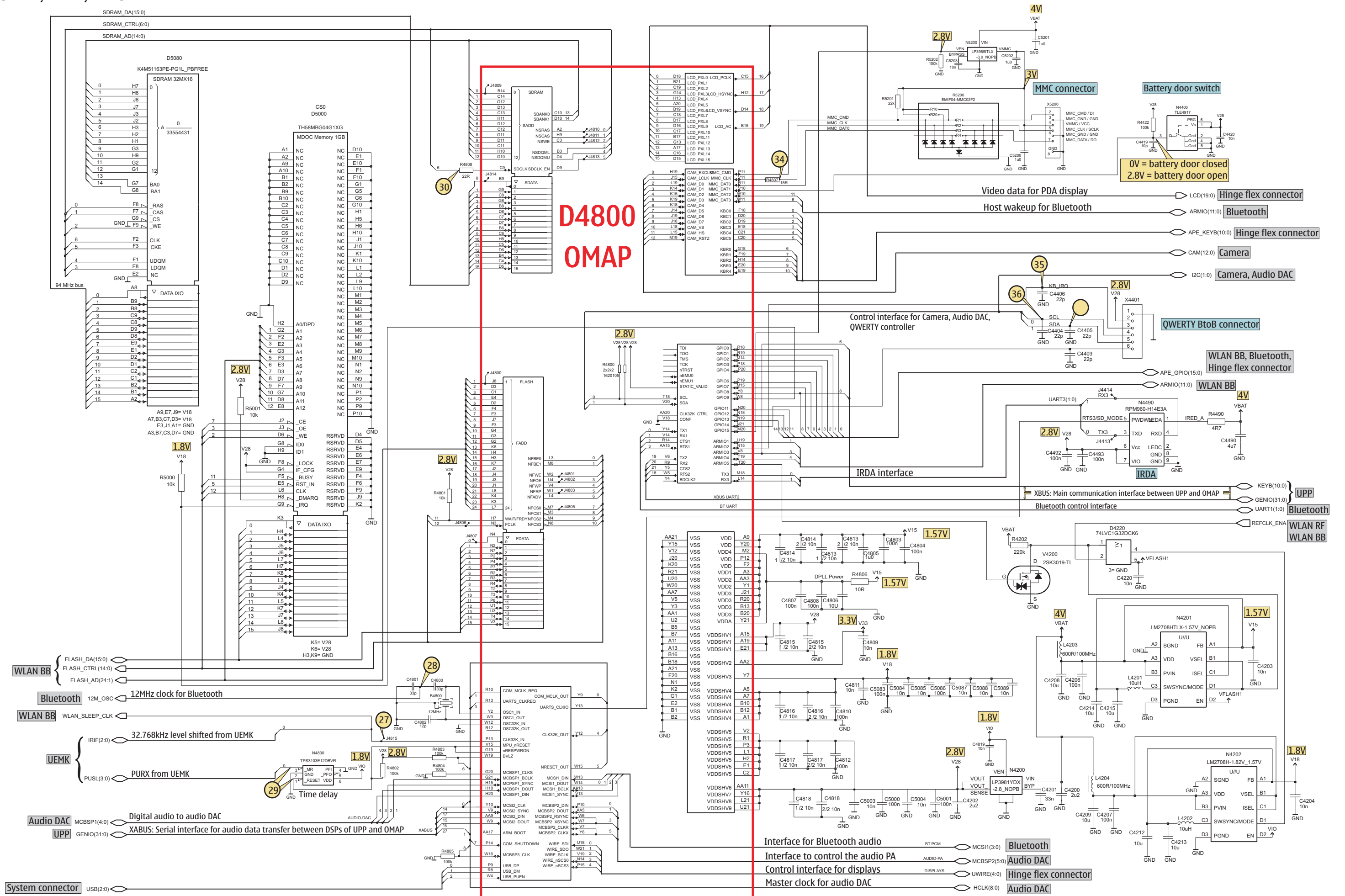

Audio DAC, Audio amplifier

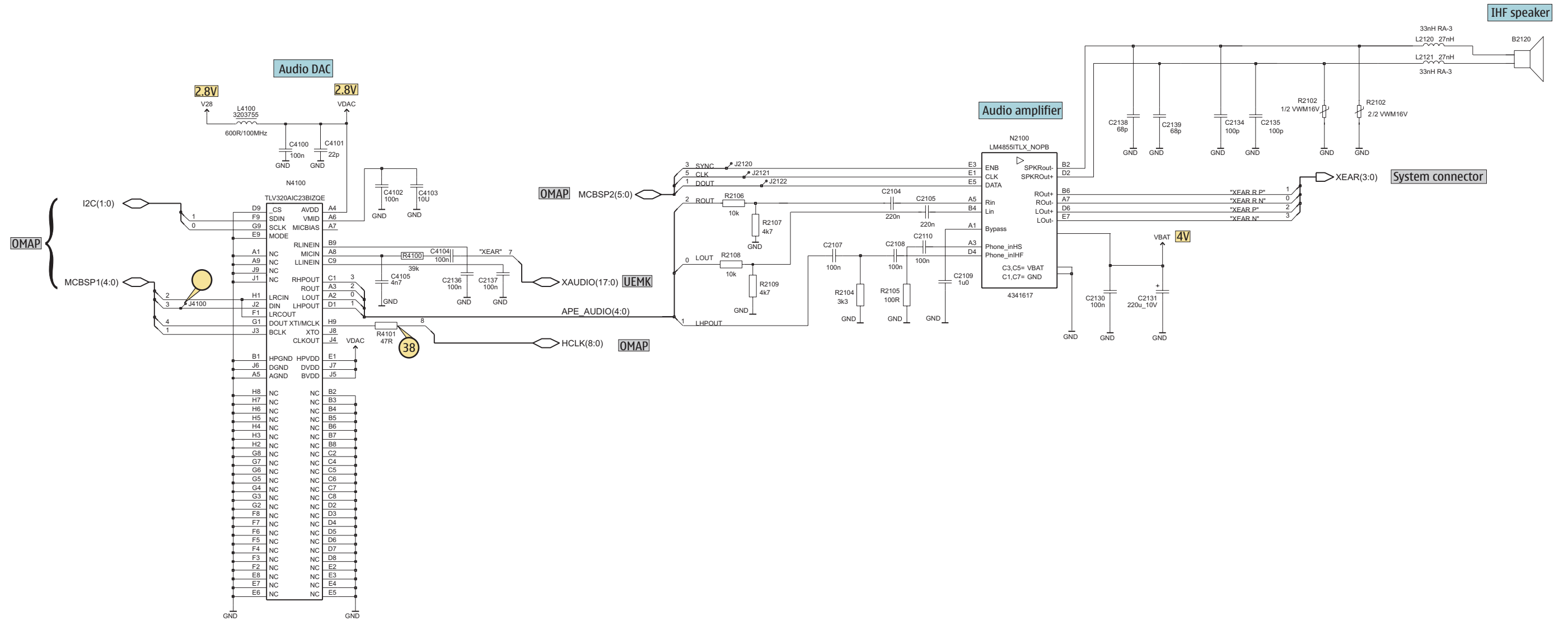

Bluetooth

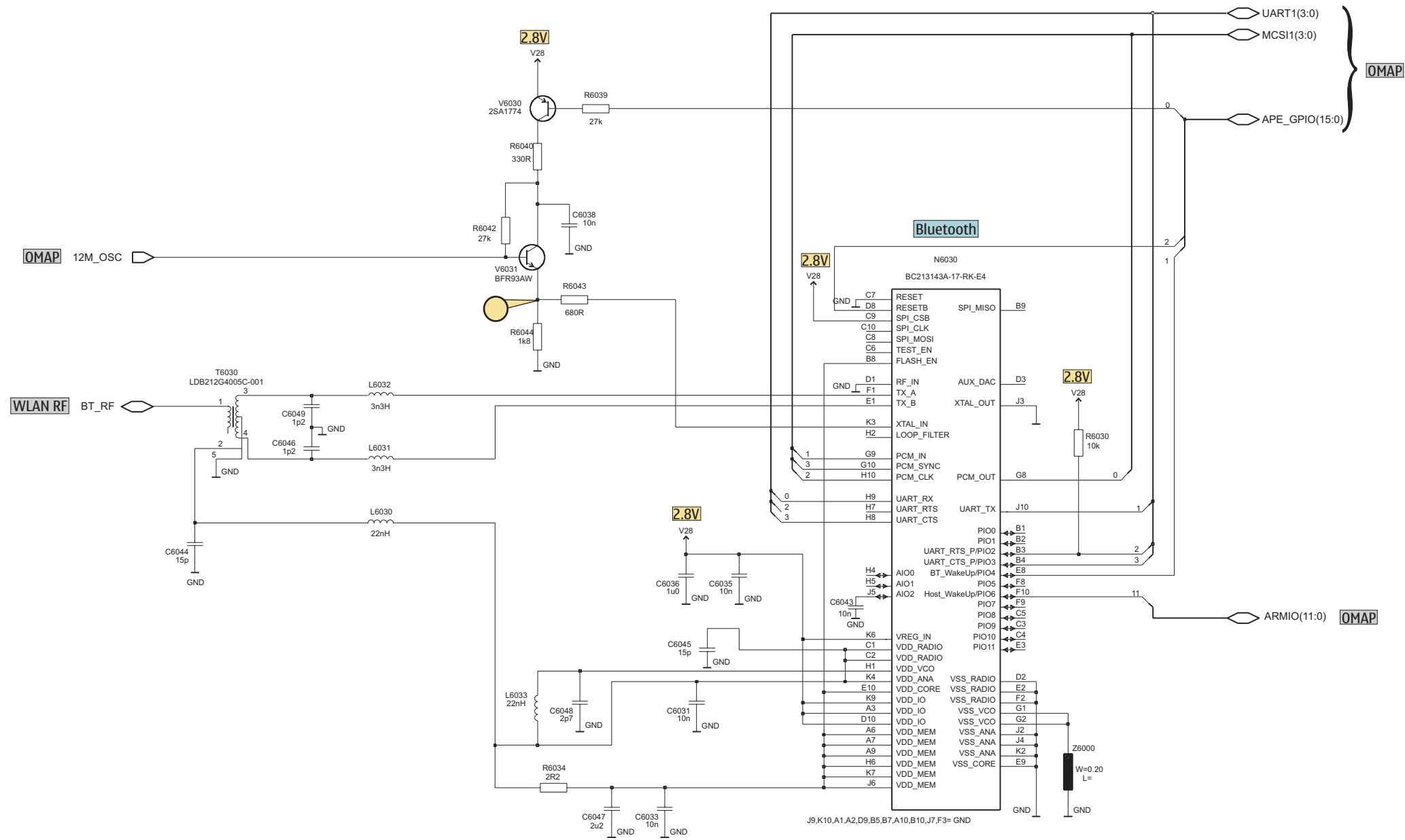

Hinge Camera flex connector, interface

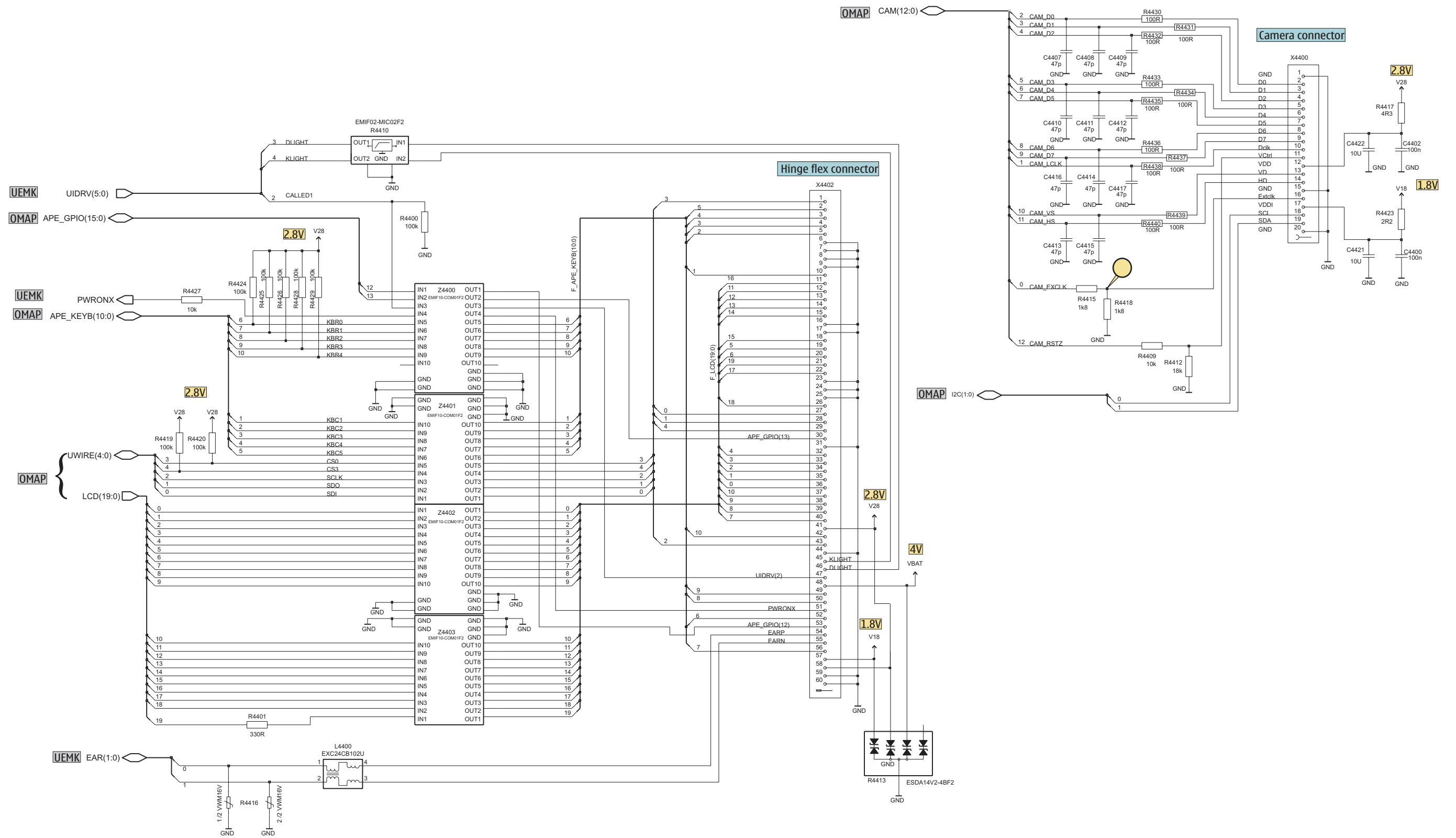

WLAN baseband

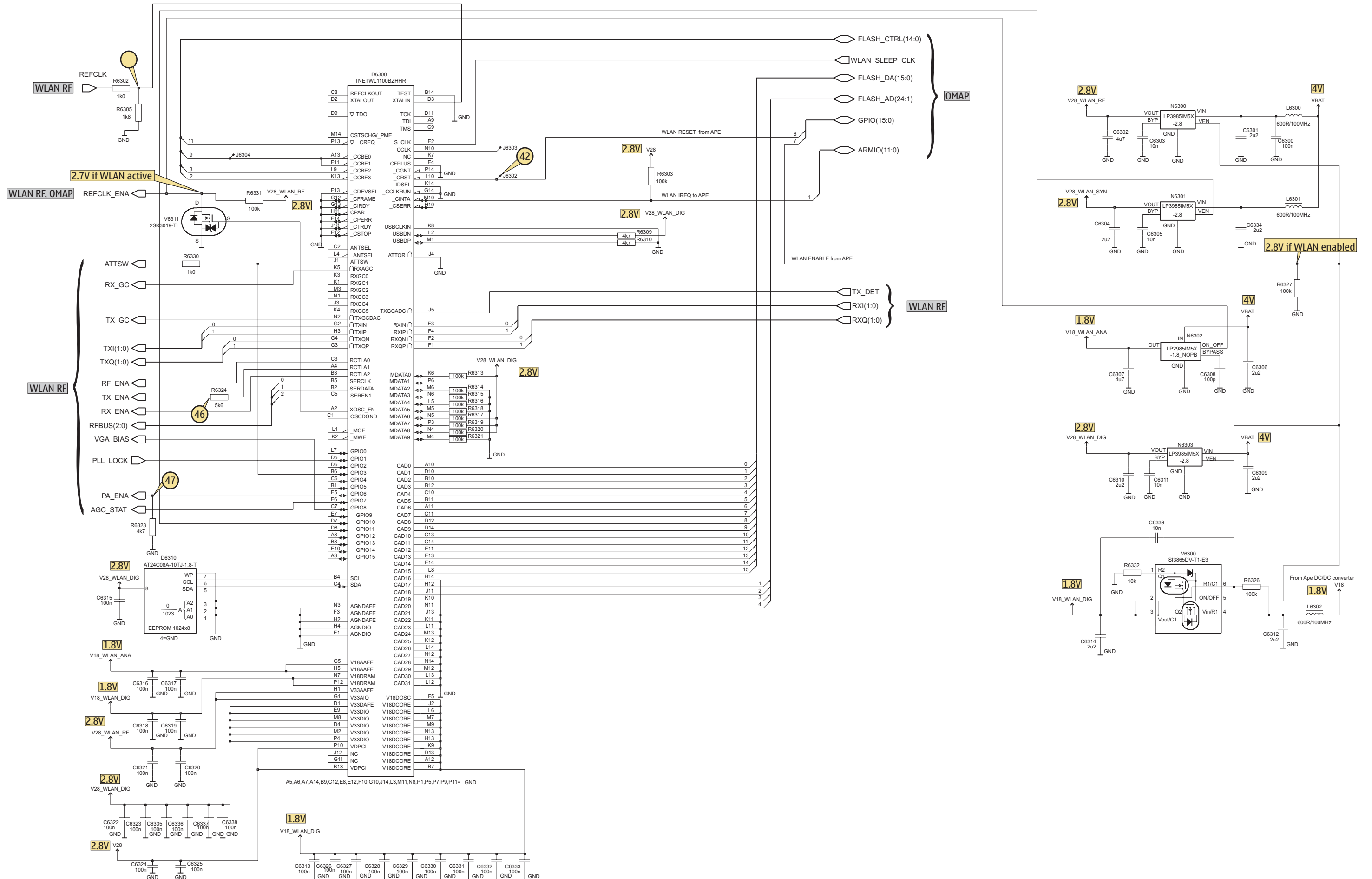

WLAN RF

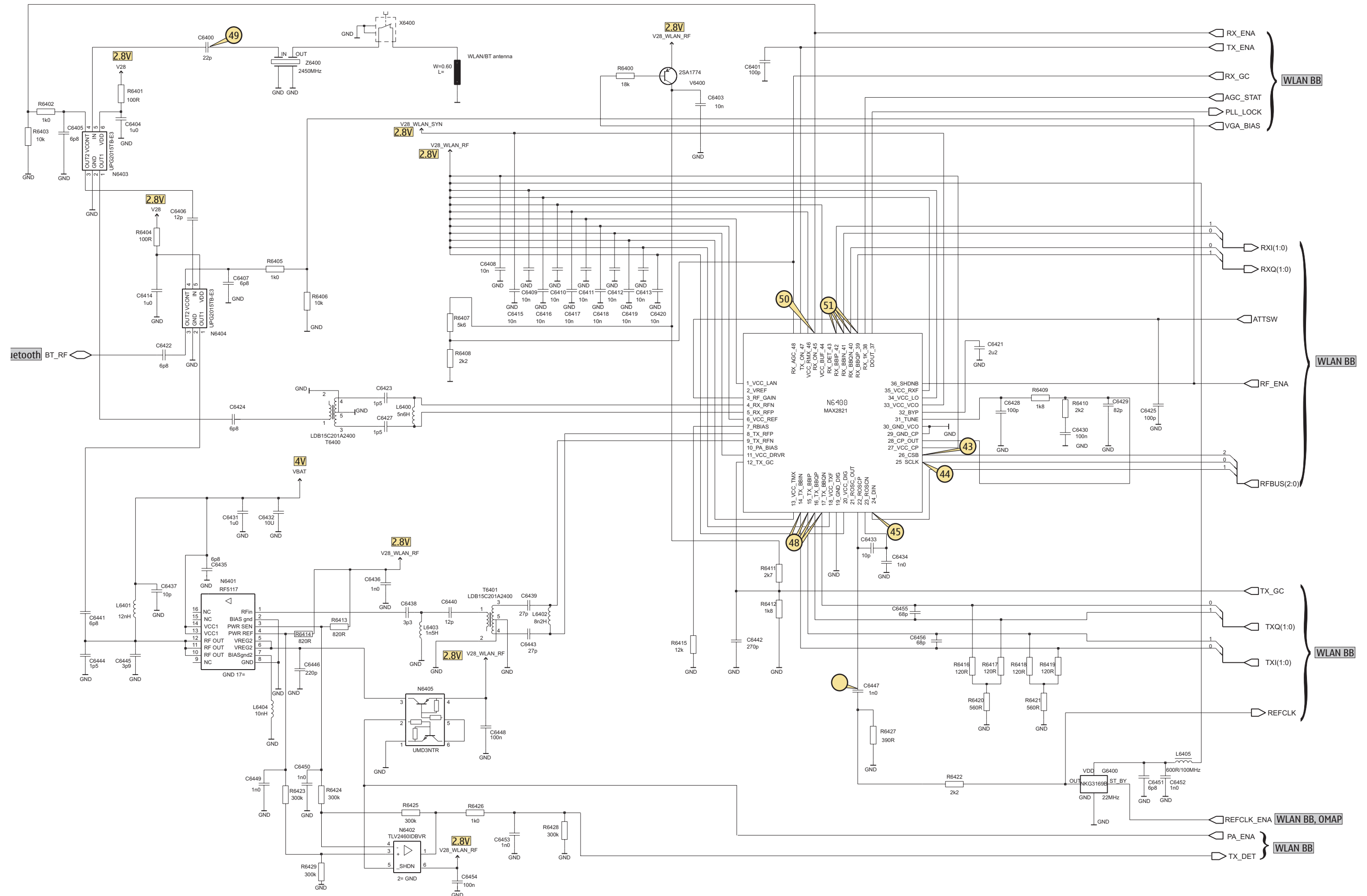

Flex foil

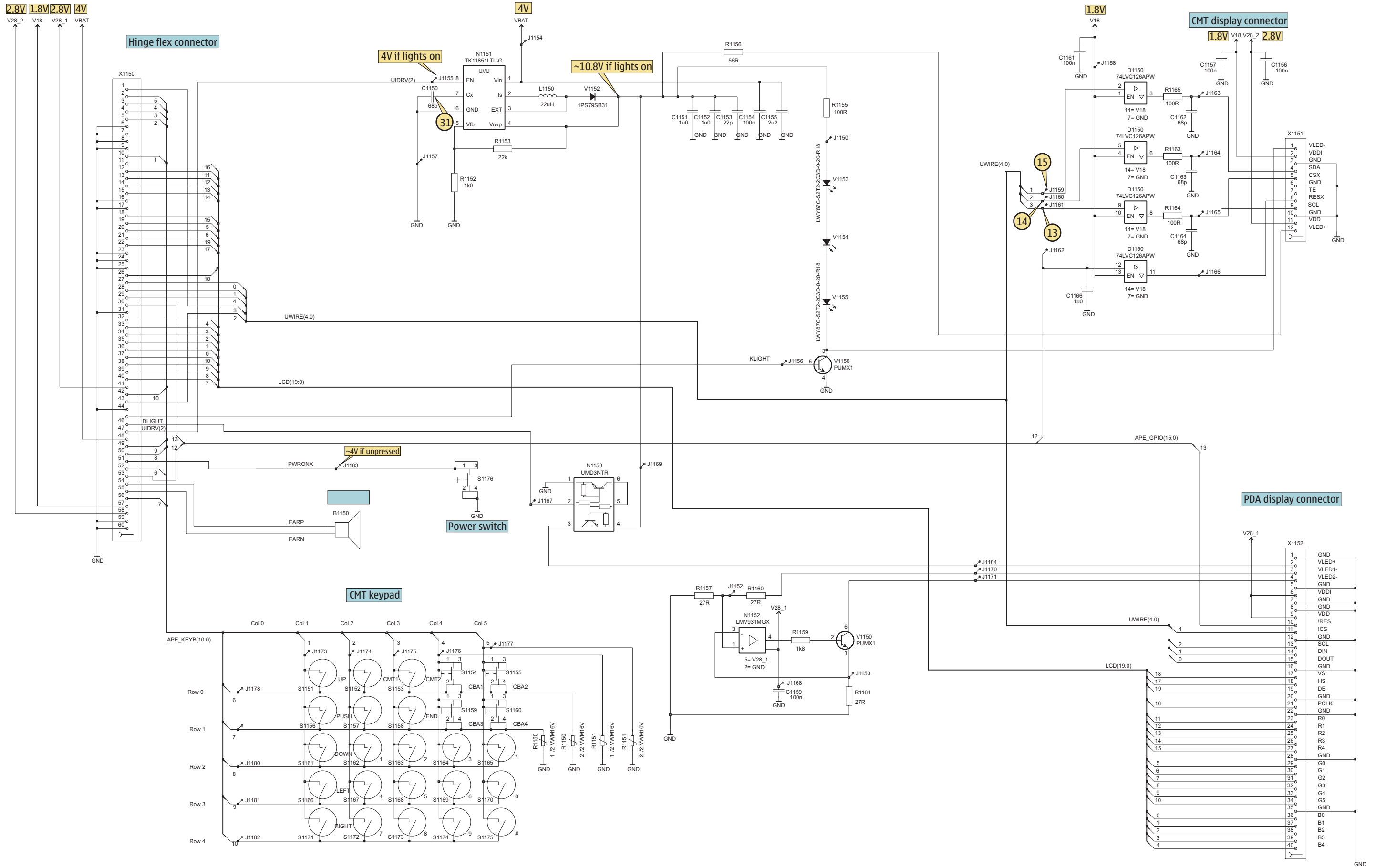

QWERTY keyboard

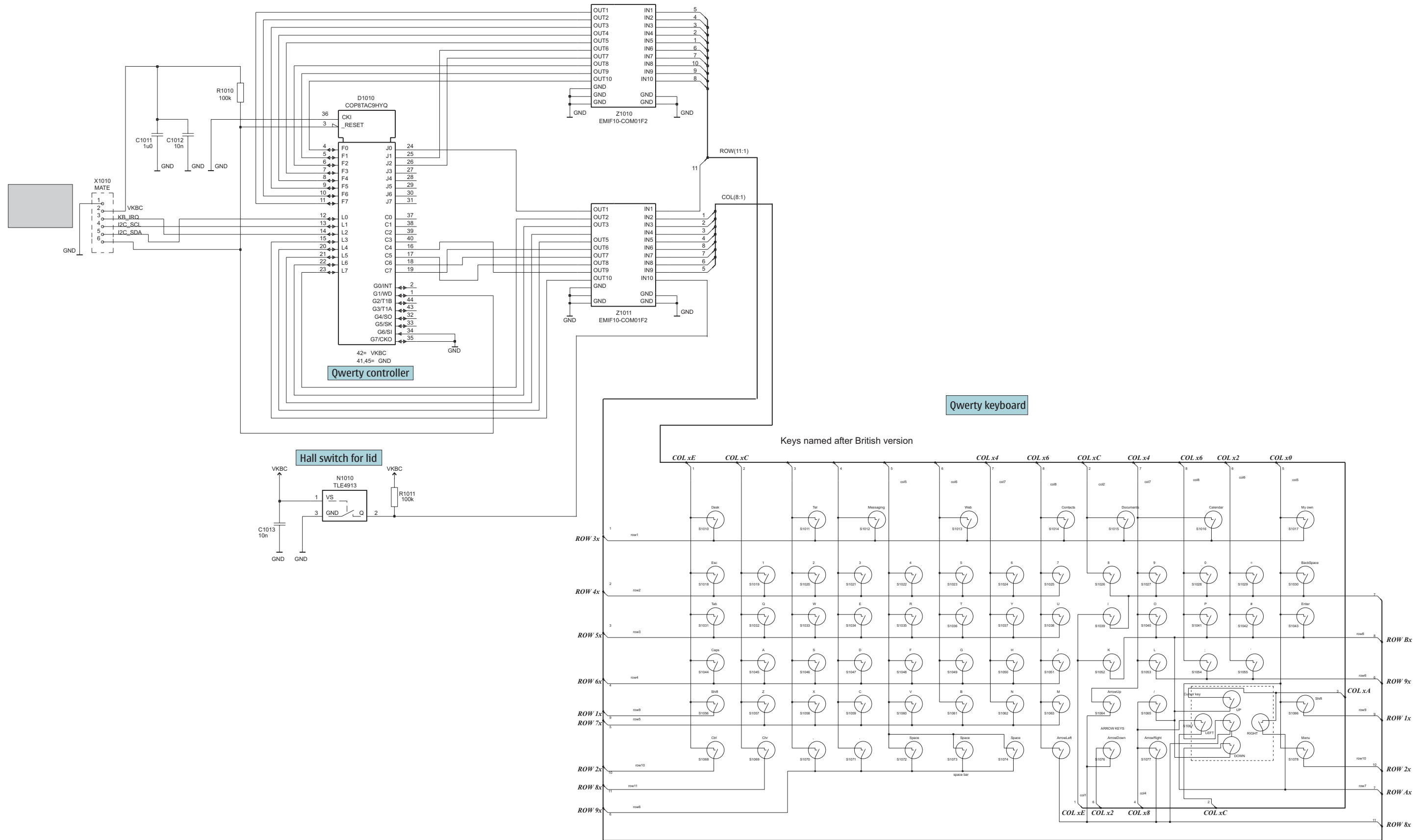

RF-part

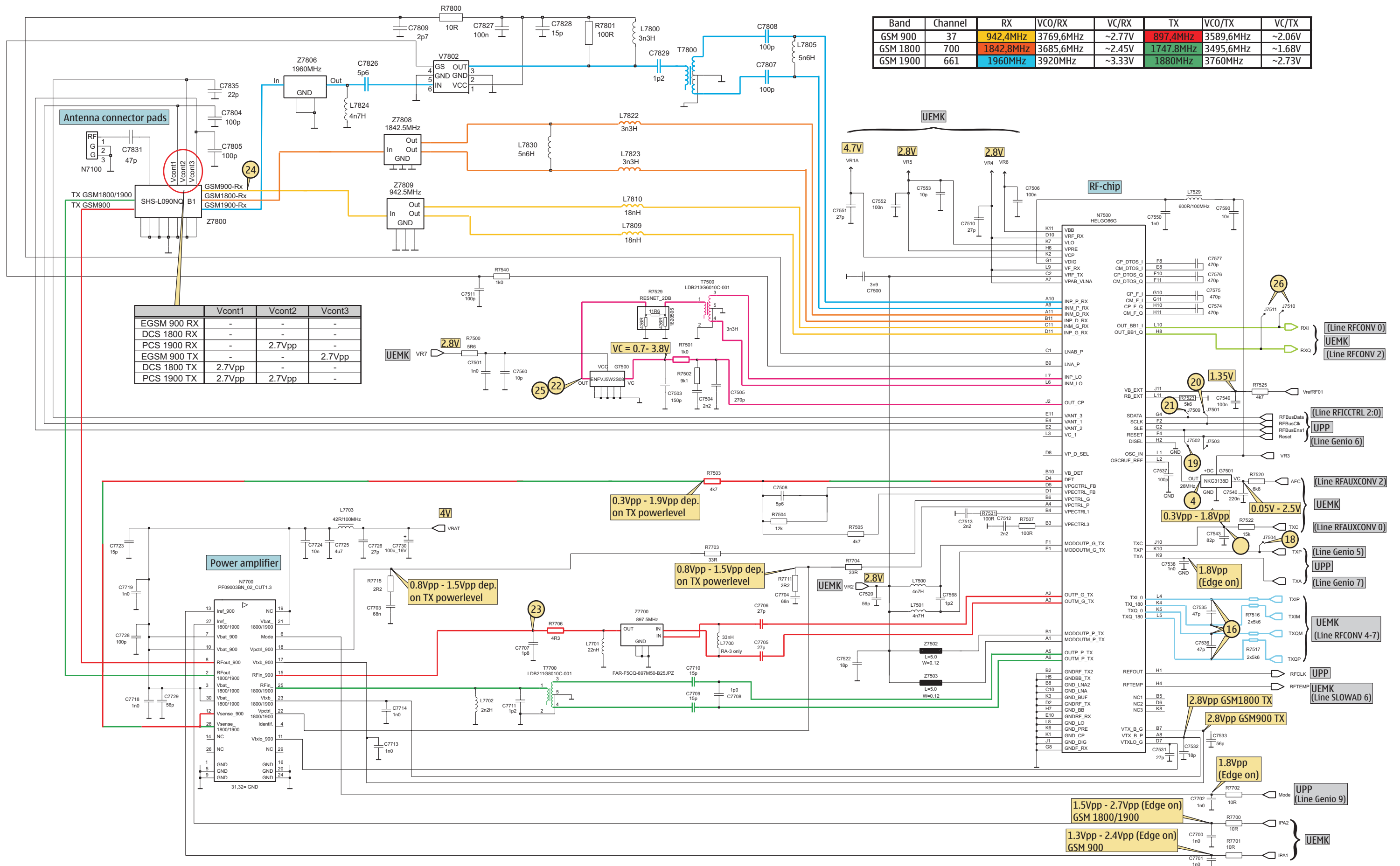

Signal overview Side 1

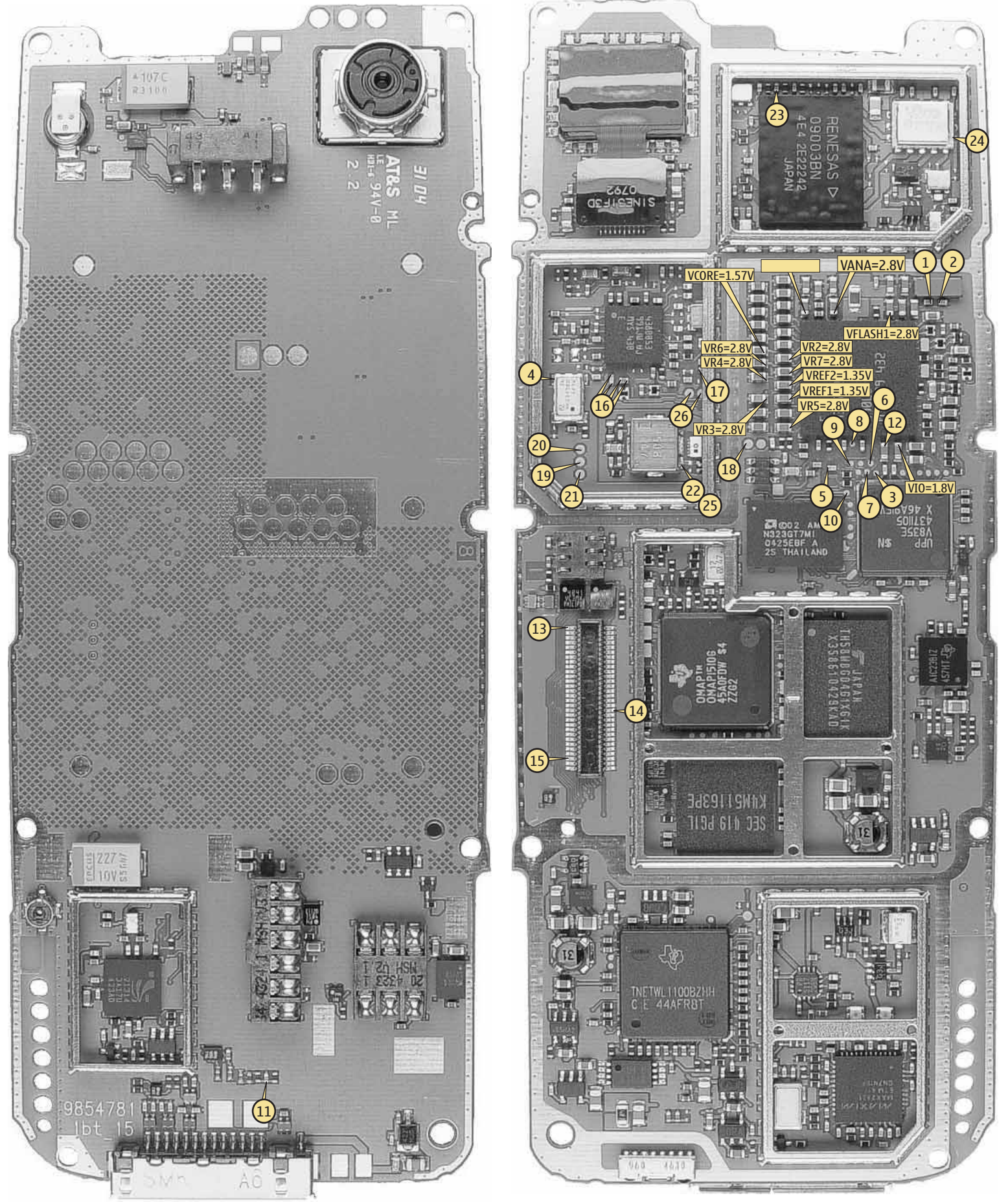
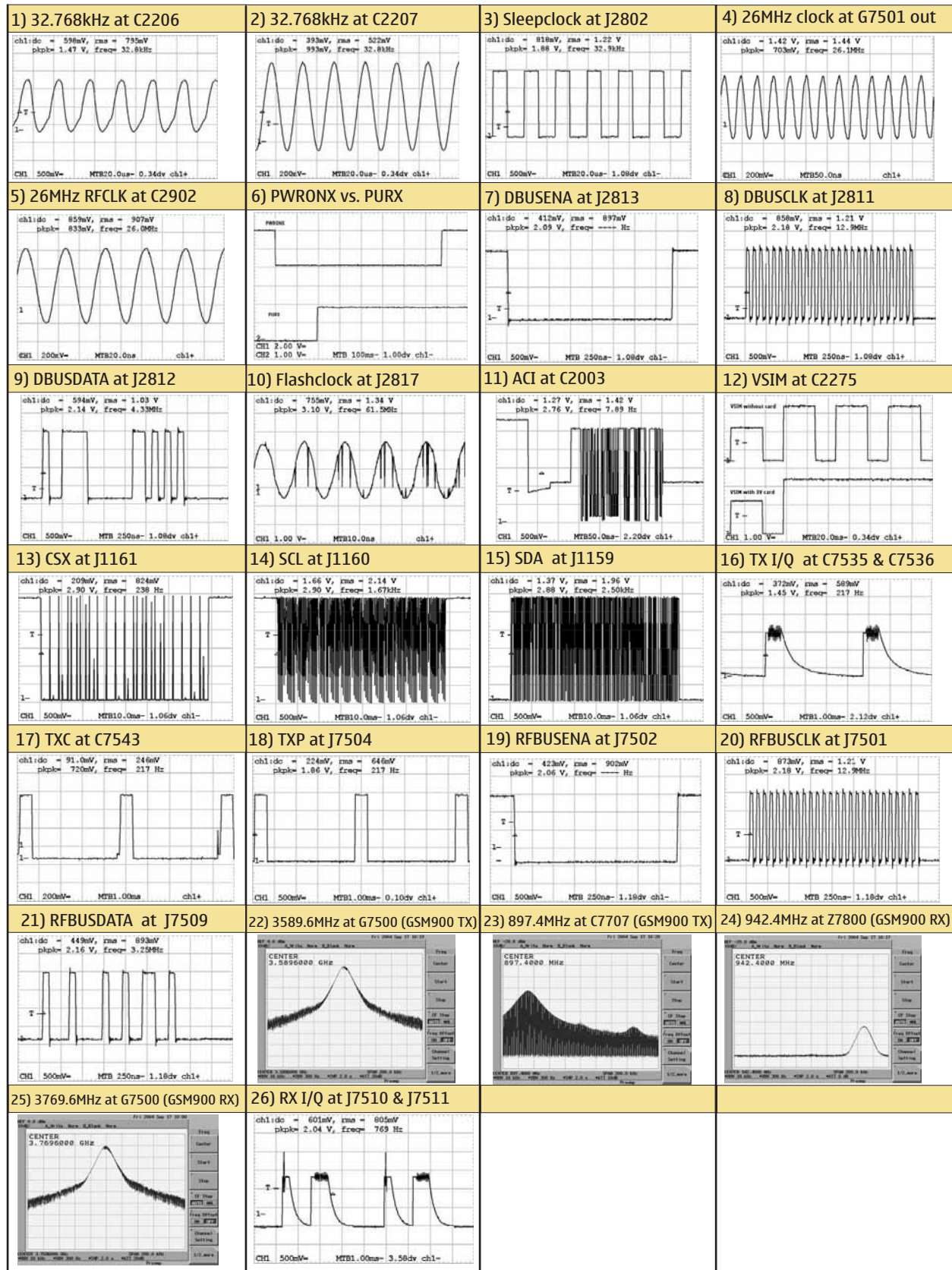

Signal overview Side 2

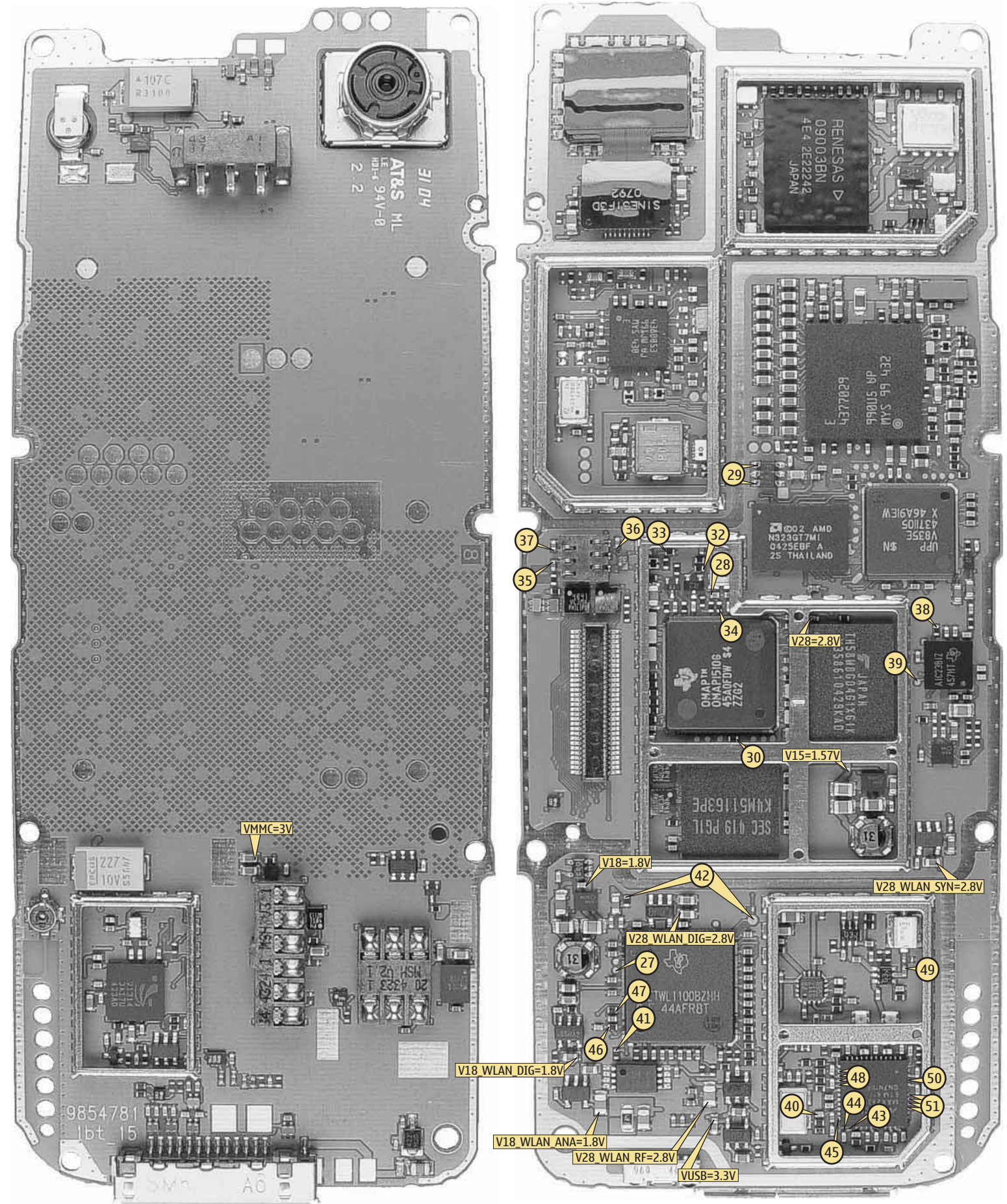
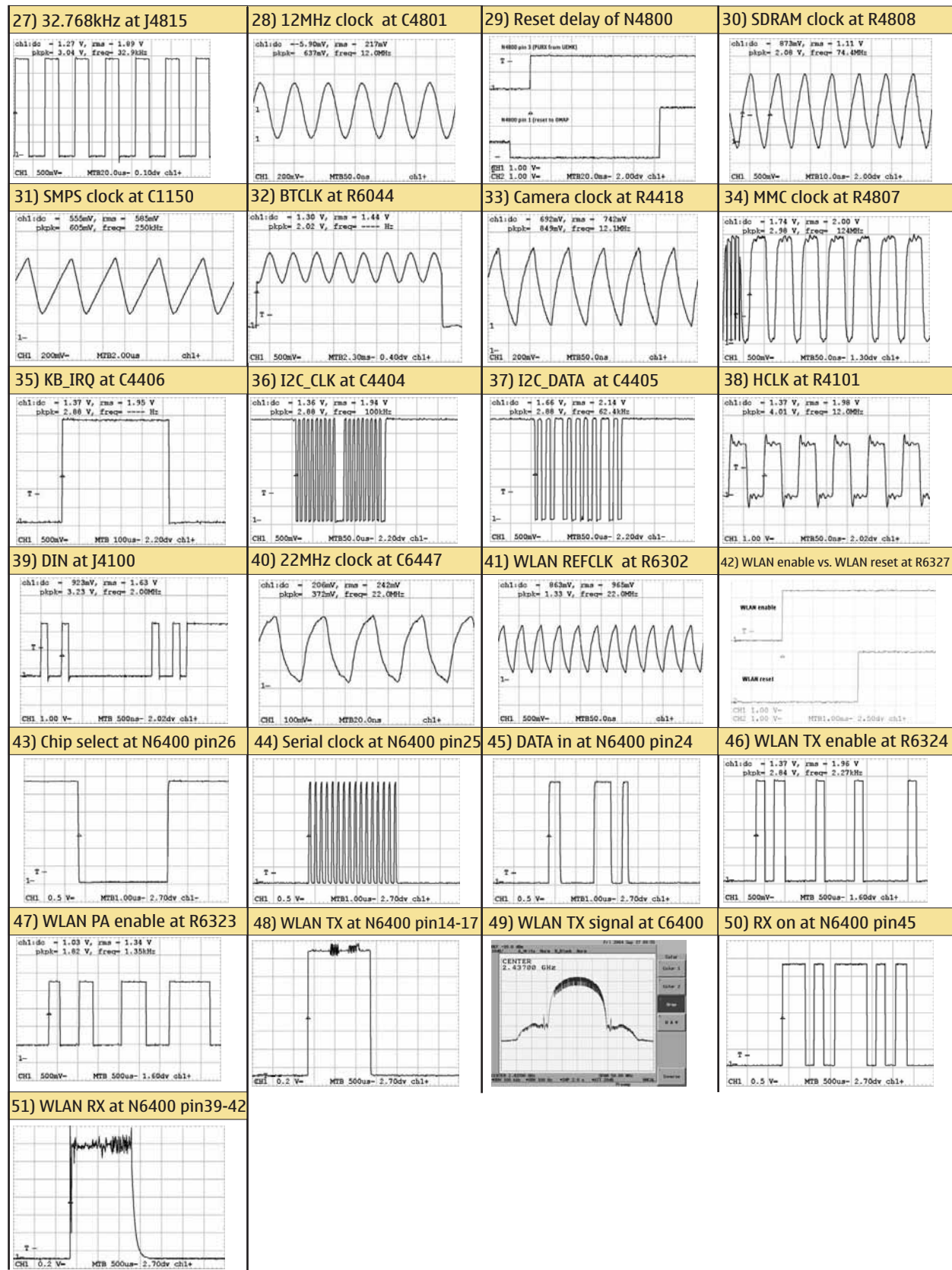

Component finder Bottom side

C	C5201	G6	J2021	R6	J4413	I8	R2003	C5	R6425	C3	
C2003	C6	C5202	G6	J2022	R7	J4414	I7	R2005	B4	R6429	D4
C2004	C5	C5203	G6	J2025	T2	L	R2007	B4	T		
C2008	B3	C6031	E2	J2026	T9	L2000	C5	R2025	W5	T6030	F3
C2009	B4	C6033	D3	J2027	I9	L2001	C5	R2028	C4	V	
C2010	B4	C6035	E2	J2028	I2	L2002	C5	R2029	C4	V2020	B9
C2011	B4	C6036	D2	J2029	O9	L2003	B4	R2030	C3	V4200	G9
C2012	B4	C6043	D3	J2031	W3	L2004	B4	R2031	B3	V6400	C3
C2013	B4	C6044	F3	J2032	W4	L2005	B3	R2035	W5	X	
C2026	A9	C6045	E4	J2033	W3	L2020	A9	R2044	C6	X2020	V5
C2030	B9	C6046	F3	J2060	O7	L2120	X6	R2071	W3	X2021	A5
C2037	C4	C6047	D3	J2120	L2	L2121	X6	R2072	W3	X2025	V3
C2038	C4	C6048	E2	J2121	L2	L6030	F3	R2102	X5	X2700	E9
C2070	W3	C6049	F3	J2122	L2	L6031	E3	R2124	B6	X5200	F6
C2123	B6	C6403	D3	J3100	O2	L6032	E3	R2700	E7	X6400	F1
C2131	G3	C6449	D4	J3101	P2	L6033	E2	R2701	D8		
C2134	X5	C6450	C3	J3102	O2	N	R4202	F9			
C2135	X5	C6454	C4	J3103	P3	N2070	W3	R4422	G8		
C2400	V2	C7726	X3	J3104	O3	N4400	G9	R5200	F7		
C2700	D9	C7730	X4	J3106	P3	N5200	G6	R5201	F7		
C4200	E10	F	J3107	P4	N6030	E3	R5202	G6			
C4201	D10	F2020	A9	J3108	O4	N6402	C4	R6030	F4		
C4202	F9	G	J3109	O3	N7100	Y8	R6034	D3			
C4419	G8	G2400	W2	J3180	N2	R	R6400	C3			
C4420	G9	J	J3181	N2	R2001	C6	R6423	D4			
C5200	F7	J2020	R6	J3182	O2	R2002	C6	R6424	C3		

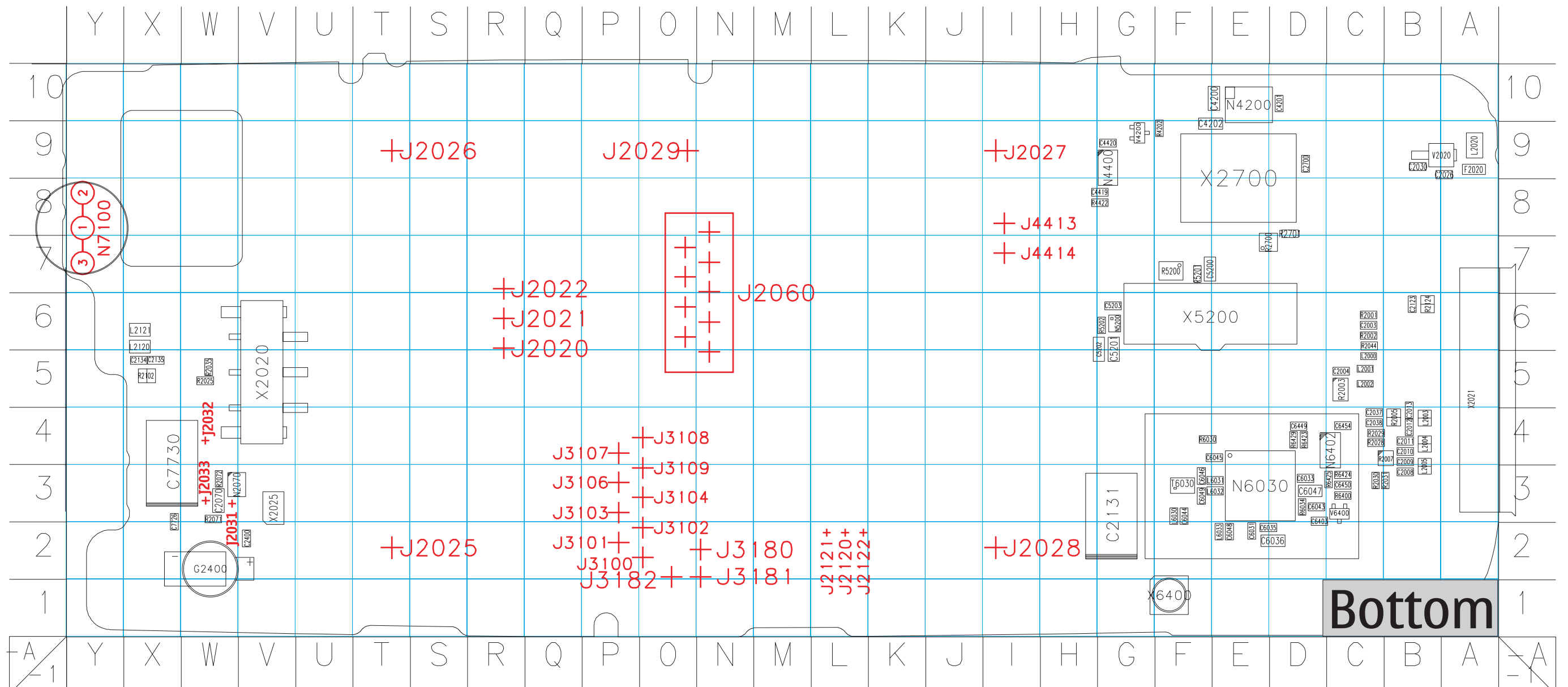

Component finder Top side

B	C2128	R1	C2214	P2	C2273	S5	C3181	N1	C4404	N9	C4804	L5	C5086	H5	C6318	F6	C6401	D9	C6427	D3	C6452	C5	C7538	Q7	C7708	S8	D	J2811	P4	J4815	E9	L4400	M10	L7830	U2	R	R2202	P2	R4420	M10	R4803	M7	R6318	D6	R6413	D4	R7522	R7	V				
B2200	S2	C2129	R2	C2215	P3	C2274	S5	C3182	O1	C4405	N10	C4805	J8	C5087	I5	C6319	D6	C6404	E3	C6428	B3	C6453	D5	C7540	P9	C7709	U6	D2200	Q3	J2812	P4	J6302	F6	L6300	B7	N	R2000	N1	R2203	P2	R4423	U10	R4804	K8	R6319	D6	R6414	E4	R7523	Q7	V6030	M7	
B4800	M6	C2130	J2	C2216	P4	C2275	P3	C3183	O1	C4406	N10	C4806	M8	C5088	I5	C6320	C7	C6405	E3	C6429	B4	C6455	C4	C7543	R7	C7710	U6	D2800	N2	J2813	O3	J6303	F6	L6301	H2	N2000	N1	R2004	A6	R2204	P2	R4424	K8	R4805	L4	R6320	C6	R6415	D3	R7525	R7	V6031	M7
C	C2132	Q1	C2217	P4	C2276	S4	C4100	K2	C4407	V9	C4807	M7	C5089	H5	C6321	C7	C6406	E4	C6430	B3	C6456	C4	C7549	R7	C7711	T5	D3000	N5	J2814	O4	J6304	E9	L6302	E10	N2001	B6	R2008	S3	R2205	P2	R4425	K8	R4806	M7	R6321	C6	R6416	C4	R7529	O7	V6300	D10	
C2000	M1	C2133	R1	C2218	P5	C2277	R5	C4101	L2	C4408	V9	C4808	L5	C6038	M7	C6322	C8	C6407	F3	C6431	F5	C7500	R10	C7550	R9	C7713	W6	D4220	G9	J2815	N4	J7501	P9	L6400	C3	N2100	J2	R2021	M4	R2206	O1	R4426	J8	R4807	M6	R6323	D9	R6417	C4	R7531	T8	V6311	A5
C2001	N1	C2136	L2	C2219	Q5	C2330	R5	C4102	K1	C4409	U9	C4809	L5	C6300	C7	C6323	D9	C6408	B4	C6432	F5	C7501	P9	C7551	R9	C7714	U6	D4800	K6	J2816	O4	J7502	P9	L6401	F5	N4100	K2	R2104	J2	R2900	P5	R4427	L8	R4808	J6	R6324	D9	R6418	C4	R7540	U2	V7802	U2
C2002	M1	C2137	L2	C2220	Q5	C2331	S4	C4103	K1	C4410	U9	C4810	K5	C6301	B6	C6324	F9	C6409	B3	C6433	B4	C7503	P8	C7552	Q7	C7718	X4	D5000	K4	J2817	O4	J7503	P5	L6402	C3	N4200	E10	R2105	J2	R2901	P5	R4428	K8	R5000	J3	R6326	D9	R6419	C4	R7700	T5	X	
C2005	B7	C2138	K1	C2221	Q5	C2332	S5	C4104	M1	C4411	V9	C4811	M6	C6302	C7	C6325	E6	C6410	C2	C6434	B4	C7504	P8	C7553	Q8	C7719	V6	D5080	I6	J2818	N4	J7504	P6	L6403	D4	N4201	I3	R2106	J1	R2902	O4	R4429	K8	R5001	J3	R6327	G8	R6420	C5	R7701	X5	X4400	U8
C2006	A6	C2139	K1	C2222	P5	C2333	S5	C4105	L1	C4412	V8	C4812	L4	C6303	C6	C6326	C7	C6411	C2	C6435	E5	C7505	Q9	C7560	P8	C7723	T4	D6300	E7	J3105	O2	J7509	O9	L6404	E4	N4202	G9	R2107	J1	R2903	P4	R4430	V9	R6039	M7	R6330	D2	R6421	C5	R7702	T3	X4401	N9
C2007	B6	C2200	S3	C2223	Q5	C2334	R5	C4203	I4	C4413	V7	C4813	L8	C6304	G2	C6327	E9	C6412	C4	C6436	D4	C7506	R7	C7568	R9	C7724	X3	D6310	C8	J4100	K2	J7510	Q7	L6405	C5	N4490	A8	R2108	J1	R3000	O4	R4431	V9	R6040	M8	R6331	A5	R6422	B4	R7703	V6	X4402	K9
C2104	I1	C2201	S3	C2224	Q2	C2335	P2	C4204	G9	C4414	V8	C4814	J5	C6305	G2	C6328	C8	C6413	B4	C6437	F5	C7508	S9	C7574	R7	C7725	W3	G	J4800	K5	J7511	Q7	L7500	R9	N4800	O5	R2109	J1	R4100	L1	R4432	U9	R6042	M7	R6332	C10	R6426	D5	R7704	V6	Z		
C2105	J1	C2202	S3	C2225	P2	C2880	O3	C4206	I3	C4415	U7	C4815	L8	C6306	C9	C6329	F7	C6414	E4	C6438	D5	C7510	S8	C7575	R7	C7728	V6	G6400	B5	J4801	L5	L	L7501	S9	N6300	C6	R2120	R2	R4101	L2	R4433	U9	R6043	N7	R6401	E3	R6427	B4	R7706	X5	Z4400	M9	
C2107	J2	C2203	S4	C2226	Q2	C2881	M2	C4207	F9	C4416	V7	C4816	J5	C6307	B9	C6330	F8	C6415	B3	C6439	D4	C7511	U2	C7576	R7	C7729	V3	G7500	P8	J4802	L5	L2330	R5	L7529	R9	N6301	H2	R2121	R1	R4400	M8	R4434	V9	R6044	M7	R6402	E3	R6428	D5	R7710	X5	Z4401	M9
C2108	J2	C2204	P3	C2227	P2	C2882	M3	C4208	I3	C4417	V7	C4817	K5	C6308	C10	C6331	F6	C6416	B3	C6440	D4	C7512	T9	C7577	R7	C7804	X1	G7501	Q9	J4803	L5	L2331	S4	L7701	X5	N6302	C9	R2122	R2	R4401	H7	R4435	V8	R6302	C9	R6403	E3	R7500	O8	R7711	U6	Z4402	I8
C2109	J2	C2205	R5	C2228	R5	C2883	O1	C4209	F9	C4421	U9	C4818	L8	C6309	G7	C6332	E6	C6417	C2	C6441	F4	C7513	T8	C7590	R9	C7805	X2	J	J4805	K5	L2332	S5	L7702	T5	N6303	F8	R2123	R2	R4409	U7	R4436	V8	R6303	E6	R6404	F4	R7501	P8	R7715	W6	Z6400	F3	
C2110	J2	C2206	S2	C2229	R5	C2884	O3	C4212	F10	C4422	U7	C4819	P5	C6310	F7	C6333	H6	C6418	C3	C6442	D4	C7520	S9	C7700	T4	C7807	U1	J2800	P3	J4806	K5	L2333	S5	L7703	X3	N6400	C3	R2125	R1	R4410	N8	R4437	V8	R6305	C8	R6405	F3	R7502	P9	R7800	U3	Z7700	W6
C2120	R1	C2207	S2	C2230	Q5	C2885	M2	C4213	G10	C4490	B8	C5000	J4	C6311	F8	C6334	H2	C6419	C4	C6443	D3	C7522	S10	C7701	X5	C7808	U1	J2801	O3	J4807	K5	L2334	S5	L7800	T2	N6401	E5	R2126	Q2	R4412	U7	R4438	V8	R6309	C7	R6406	F3	R7503	T9	R7801	U2	Z4403	I8
C2121	R2	C2208	S2	C2231	P5	C2900	P5	C4214	I4	C4492	B7	C5001	J3	C6312	E10	C6335	E9	C6420	B4	C6444	F4	C7531	X4	C7702	T3	C7826	U3	J2802	O3	J4809	J7	L2335	P2	L7805	S8	N6403	E3	R2127	Q1	R4413	I10	R4439	U7	R6310	C6	R6407	D2	R7504	S8	T	Z7800	W2	
C2122	R2	C2209	S2	C2232	Q5	C2901	P5	C4215	I4	C4493	B7	C5003	J4	C6313	E9	C6336	E6	C6421	A3	C6445	E4	C7532	T7	C7703	W6	C7827	T3	J2803	P3	J4810	J5	L4100	K2	L7809	R7	N6404	F4	R2128	Q1	R4415	N7	R4440	U7	R6313	C7	R6408	C2	R7505	S9	T6400	D3	Z7806	V2
C2124	Q2	C2210	S2	C2233	Q5	C2902	O4	C4220	G10	C4800	M6	C5004	J3	C6314	C10	C6337	D6	C6422	F4	C6446	E4	C7533	T7	C7704	U6	C7828	T3	J2807	O2	J4811	J6	L4201	H3	L7810	S7	N6405	D5	R2129	R2	R4416	M10	R4490	B8	R6314	C6	R6409	A3	R7507	T9	T6401	D3	Z7808	V2
C2125	Q2	C2211	S2	C2270	S4	C3030	P4	C4400	U9	C4801	M6	C5083	H5	C6315	C7	C6338	C6	C6423	D3	C6447	B4	C7535	Q8	C7705	S9	C7829	T2	J2808	O2	J4812	J5	L4202	E9	L7822	S7	N7500	R8	R2130	Q2	R4417	U7	R4800	N8	R6315	D6	R6410	A4	R7516	Q8	T7500	P7	Z7809	S7
C2126	R1	C2212	Q2	C2271	S4	C3031	O4	C4402	U7	C4802	N7	C5084	H7	C6316	C8	C6339	D10	C6424	E3	C6448	D5	C7536	Q8	C7706	S8	C7831	X2	J2809	O3	J4813	J7	L4203	I3	L7823	S7	N7700	V4	R2200	S3	R4418	N7	R4801	K5	R6316	C6	R6411	C4	R7517	Q8	T7700	T6		
C2127	R2	C2213	Q1	C2272	S5	C3032	O5	C4403	N8	C4803	J8	C5085	H7	C6317	C7	C6400	E3	C6425	C3	C6451	C5	C7537	Q9	C7707	X5	C7835	X2	J2810	O2	J4814	J6	L4204	G9	L7824	U3			R2201	P2	R4419	M10	R4802	M7	R6317	D6	R6412	D4	R7520	P9	T7800	U2		

